

# Disassembly Instructions, EasyPac, Across 1xCompactor

Rev. Date: 2016-11-10 – SPID: 1150/0.8 (-) – Disassembly Instructions, EasyPac, Across 1xCompactor – Basic 90137002-Tomra EasyPac Unit Across 1xComp

<b>Notice</b>	<ul style="list-style-type: none"> <li>• There are variants of this module, causing minor individual weight variations.</li> <li>• Parts containing plastic, steel and cables should be separated. Printed circuit boards should be separated from steel.</li> </ul>	
---------------	--	---

<b>Suggested tools</b>	<ul style="list-style-type: none"> <li>• Socket wrenches 7, 8, 10 and 30 mm</li> <li>• Wrenches 10, 24 and 30 mm</li> <li>• Torx screwdriver T20</li> <li>• Hex keys 2.5 and 4 mm</li> <li>• Side cutting pliers, medium</li> <li>• Power drill with 5mm drill bit</li> </ul>
------------------------	---

<b>Part number</b>	90137002	<b>Name</b>	Tomra EasyPac Unit Across 1xComp
--------------------	----------	-------------	----------------------------------

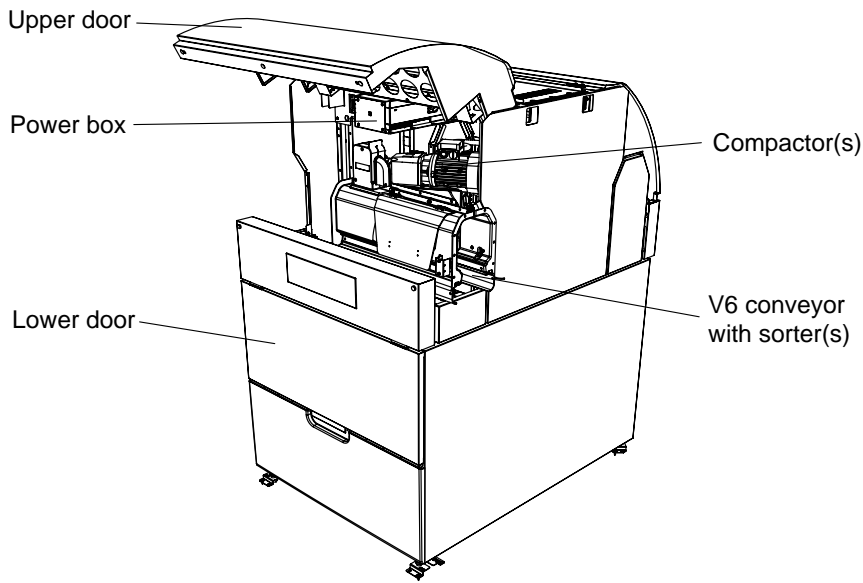

<b>Material type and weight (approximate)</b>	<b>Steel and Iron</b>	140 kg	<b>Plastics</b>	2 kg	<b>Cables</b>	2 kg
	<b>Aluminum</b>	1 kg	<b>Rubber</b>	–	<b>Other</b>	–
	<b>EEE parts</b>	10.5 kg	<b>Zink</b>	2.2 kg	<b>Other</b>	–

**Dismantling procedure** 70137200-Manual Service EasyPac

<b>Suggested dismantling procedure</b>		
Step	Part	Material
1	Upper doors (front and back)	Steel, Iron
2	Lower door	Steel, Iron, Plastic
3	V6 conveyor with sorter(s)	Steel, Iron, Plastic, Cable (EEE), Motor
4	Compactor(s)	Steel, Motor, Cable (EEE)
5	Power box	EEE part, Plastic, PCB
6	Cables, photocells, switches	Cable (EEE)